

Stainless Steel Butterfly Valves



SERIES

486

ANSI and Metric
Flange Compatible

posi-flate[®]
butterfly valves

All stainless steel butterfly valve

The Series 486 inflatable seated butterfly valve from Posi-flate features a fully machined 316L stainless steel housing. The single piece disc and shaft is available in a number of materials including 316L stainless steel and hastelloy. The disc may be polished to a mirror finish or coated with PTFE, nylon or other high performance coating.

The stainless steel valve is ideal for powders, granules, slurries and liquids and is available in sizes 2" (50mm) to 20" (500mm). Typical applications include loading and unloading of process material, sterile air control, and outlet valves for storage containers or hoppers.

Unique inflatable seat provides better seal, less wear, longer life

Posi-flate's unique inflatable seat design provides a better seal by utilizing air pressure to expand the seat against the disc, providing more sealing area and an even pressure distribution against the disc every time. The inflatable seat automatically compensates for wear when it inflates against the disc which extends the valve life considerably.

Torque requirements are substantially lower with the Posi-flate butterfly valve since the disc does not impinge the seat. The smooth profile of the disc provides minimum flow resistance and reduces material build-up.

How it works

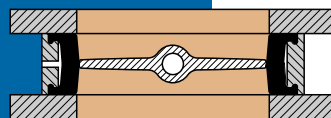

Closed, unsealed

As the valve rotates into the closed position, the disc makes only casual contact with the seat, reducing friction, wear and torque requirements.

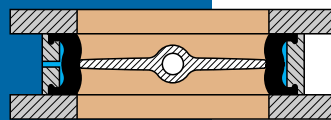

Closed, sealed

After the valve is closed, the seat inflates against the disc providing more sealing surface and an even pressure distribution against the disc.

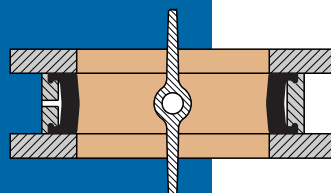

Open, unsealed

Before the valve opens, the seat is first deflated. The disc is then free to rotate to the open position.



Dimensions and Specifications

Valve Size	Posi-flate Butterfly Valves Series 486 with Stainless Steel Housing														Approx. Weight	Normal Torque	
	<div style="display: flex; justify-content: space-around; align-items: center;"> inches millimeters </div>															in. lbs.	Nm
	A	B	C	D	E	F	G	H	J	K	L	M	N	Min.		Max.	
2"/50mm	4.13	4.50	2.00	1.62	5.84	4.00	1.75	3.25	1.17	0.31	0.78	0.43	2.00	8 lbs.	40	450	
	105	114	51	41	148	102	44	83	30	8	20	11	51	3.6 kg	5	51	
3"/80mm	5.31	5.56	3.95	1.75	8.09	4.00	1.75	3.25	1.17	0.31	0.81	0.43	2.90	9 lbs.	80	450	
	135	141	100	44	205	102	44	83	30	8	21	11	74	4.1 kg	9	51	
4"/100mm	6.46	7.58	4.60	2.00	9.28	4.00	2.00	3.25	1.17	0.31	0.70	0.43	3.88	15 lbs.	130	450	
	164	193	117	51	236	102	51	83	30	8	18	11	99	6.8 kg	15	51	
5"/125mm	7.63	7.95	4.83	2.12	9.68	4.00	2.12	3.25	1.17	0.31	0.86	0.55	4.92	17 lbs.	260	450	
	194	202	123	54	246	102	54	83	30	8	22	14	125	7.7 kg	29	51	
6"/150mm	8.66	7.95	5.82	2.12	10.73	4.00	2.12	3.25	1.17	0.31	0.86	0.55	5.88	19 lbs.	300	450	
	220	202	148	54	273	102	54	83	30	8	22	14	149	8.6 kg	34	51	
8"/200mm	10.83	9.87	7.21	2.50	13.64	5.25	2.50	4.31	1.75	0.38	0.88	0.75	7.86	34 lbs.	540	700	
	275	251	183	64	346	133	64	109	44	10	22	19	200	15.4 kg	61	79	
10"/250mm	12.99	10.56	7.97	2.50	16.34	5.25	2.50	4.31	1.75	0.38	0.93	0.75	9.81	48 lbs.	860	1300	
	330	268	202	64	415	133	64	109	44	10	24	19	249	21.8 kg	97	147	
12"/300mm	14.88	14.28	9.71	3.00	18.58	4.00	4.00	2.84	2.84	0.44	1.25	0.87	11.83	88 lbs.	1240	2480	
	378	363	247	76	472	102	102	72	72	11	32	22	300	40 kg	140	280	
14"/350mm	17.25	16.00	11.38	3.00	21.05	4.00	4.00	2.84	2.84	0.44	1.02	0.87	13.08	113 lbs.	2100	6200	
	438	406	289	76	535	102	102	72	72	11	26	22	332	51.3 kg	237	701	
16"/400mm	19.33	16.93	11.75	4.00	23.10	4.75	4.75	3.48	3.48	0.53	1.29	1.06	15.02	147 lbs.	3500	9600	
	491	430	298	102	587	121	121	88	88	13	33	27	382	66.7 kg	395	1085	
18"/450mm	21.23	15.84	13.36	4.25	25.09	4.75	4.75	3.48	3.48	0.57	1.31	1.06	17.26	188 lbs.	4800	12150	
	539	402	339	108	637	121	121	88	88	14	33	27	438	85.4 kg	542	1373	
20"/500mm	23.39	17.38	14.11	5.00	27.24	5.75	5.75	3.90	3.90	0.69	1.57	1.42	18.69	211 lbs.	7800	15600	
	594	441	358	127	692	146	146	99	99	18	40	36	475	95.8 kg	881	1763	

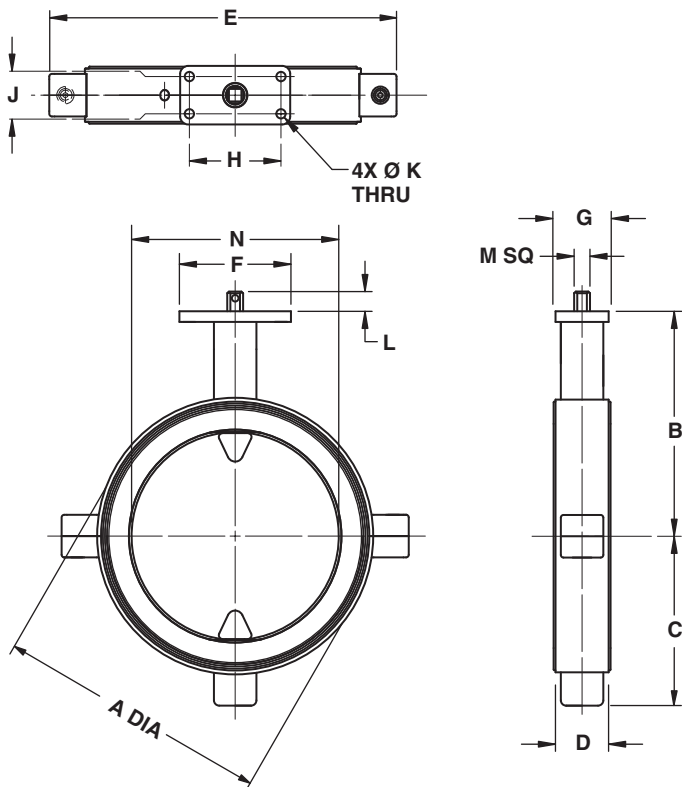

Available Materials of Construction:

Housing: 316L stainless steel housing with satin finish or polished finish

Disc/shaft: Integral 316L stainless steel disc/shaft with standard satin polish or premium polish; hastelloy disc/shaft; PTFE coating

Seat: White FDA Buna-N, white FDA silicone, white fluoroelastomer, black fluoroelastomer, black EPDM and others

Bearings: Nylon, bronze or PTFE

Shaft Seal: Buna-N or fluoroelastomer

Housing Gasket: Buna-N or silicone

Hardware: Stainless steel

All specifications subject to change without notice.

Customized materials available.

Posi-flate® is a registered trademark of Posi-flate, St. Paul, Minnesota.

Made in the U.S.A.

Foreign patents pending.

© Copyright 2008, Posi-flate®

Printed in U.S.A. • Bulletin 20801-1 (dm)

Temperature limits: -40° to 300° F (-40° to 150° C), varies with application and materials of construction.

Air supply: 115 PSIG (7.9 bar) maximum to seat, varies with application.

Working pressure: Full vacuum to 100 PSIG (6.9 bar), varies with materials of construction.

Operating torque: Varies with application.

posi-flate®

butterfly valves

Corporate Headquarters

Posi-flate • St. Paul, MN USA • +1 651 484-5800

Worldwide Offices

Brazil • China • New Zealand • United Kingdom

www.posiflate.com