



The VMAX™ Linear Vibrator operates with low noise levels and high force outputs and accommodates the most demanding of applications. Special end mounts, dual ports and a totally enclosed housing make it one of the most unique linear vibrators on the market. With a state-of-the-art piston design, the VMAX linear vibrator does not require a spring to start and is centrifugally balanced, which prolongs the life and increases the force output over conventional models. The VMAX vibrator comes in a variety of sizes to suit almost every application, big and small.

The VMAX vibrator is suitable for many different applications, including vibratory conveying, vibratory compacting and discharging of either dry or wet difficult to handle bulk solids from bins and hoppers. The VMAX linear vibrator is versatile with regard to most applications because its force output can be adjusted for a wide range of requirements by simply increasing the compressed air pressure and/or volume using conventional low cost air or electrical controls. The flexibility and range of the VMAX linear vibrator can be enhanced considerably by utilizing a two mass design, where the output force can be multiplied numerous times its normal maximum output.

The VMAX linear vibrator can also be used to compact materials when filling containers to achieve maximum space utilization and save shipping costs.

When designed into a vibratory conveyor for instance, the VMAX linear vibrator has tremendous cost and performance advantages over using an electric vibrating motor for the drive mechanism. This is because the VMAX linear vibrator starts and stops quickly and smoothly and is more controlled for significantly better performance. It does not go through a violent resonance phase like an electric vibrating motor. When an electric vibrating motor starts and/or stops, it goes through what is called a resonance phase, where the frequency of the vibrating system is at the natural frequency of the suspension. When this happens, amplification of movement occurs and the conveyor reacts violently. In addition, this violent movement takes some time to settle down and fully stop, which is not only detrimental for many applications, but can be costly to resolve as well.

Also, because the VMAX linear vibrator operates with compressed air, it is a natural for explosion proof applications and much safer to use. When used with filtered and lubricated compressed air, the VMAX linear vibrator requires only minimal maintenance.

Features and Benefits

- Standard temperature application: from 14° F (-10° C) to 300° F (150° C)
- Explosion-proof as standard
- Maintenance-free
- Adjustable frequency
- Adjustable amplitude
- Wide oscillations
- Excellent start/stop characteristics
- Starts in any position
- Minimum sound emission
- Low air consumption
- Less expensive than electric vibrators

Vibrator Performance

Force Output (Lbs.)													
Model	Air Pressure (PSI)												
	40	45	50	55	60	65	70	75	80	85	90	95	100
250	121	146	170	195	219	244	268	293	317	342	366	391	415
600	285	335	386	437	487	538	589	639	690	741	792	842	893
1500	375	497	620	743	866	988	1111	1234	1357	1479	1602	1725	1848
3000	628	819	1011	1203	1395	1586	1778	1970	2161	2353	2545	2736	2928
6000	980	1222	1465	1707	1946	2192	2434	2677	2919	3162	3404	3646	3889
10000	2516	2838	3085	3282	3455	3628	3927	4076	4400	4825	5376	6077	6954

Frequency (Hz)													
Model	Air Pressure (PSI)												
	40	45	50	55	60	65	70	75	80	85	90	95	100
250	30	31	32	33	34	35	36	38	39	40	41	42	43
600	28	28	29	30	31	32	32	33	34	35	36	36	37
1500	21	22	23	24	25	26	27	28	29	30	31	32	32
3000	17	18	19	19	20	20	21	21	22	23	23	24	24
6000	13	14	14	15	15	16	16	17	17	18	18	18	19
10000	12	12	12	13	13	14	15	16	17	18	19	20	20

Air Consumption (SCFM)													
Model	Air Pressure (PSI)												
	40	45	50	55	60	65	70	75	80	85	90	95	100
250	9	10	12	14	16	17	19	21	22	24	26	27	29
600	11	13	15	17	19	21	23	25	27	30	32	34	36
1500	13	17	20	23	26	29	33	36	39	42	46	49	52
3000	28	33	37	42	47	52	56	61	66	70	75	80	84
6000	66	73	81	88	95	102	109	116	124	131	138	145	152
10000	68	77	86	95	104	113	123	132	141	150	159	168	177

Dimensions and Specifications

Model	VMAX Vibrator 480 Series Dimensions (inches)														Approx. Weight (lbs.)
	A	B	C	D	E	F	G	H	J	K	L	M	N	O	
250	2.06	3.25	1.25	0.55	7.00	1/4 NPT	1.31	2.88	2.50	1.44	0.75	0.44	0.88	3.03	7.9
600	2.43	4.00	1.63	0.55	7.00	1/4 NPT	1.31	2.88	2.50	1.44	0.75	0.44	0.50	3.03	12.2
1500	2.81	5.00	2.00	0.55	8.63	3/8 NPT	1.50	4.13	3.41	2.06	0.75	0.44	0.91	3.94	24.2
3000	3.31	6.25	2.50	0.88	11.00	1/2 NPT	1.75	5.50	4.38	2.75	1.00	0.60	1.25	5.25	50.0
6000	4.34	8.25	3.50	0.88	13.38	3/4 NPT	2.22	6.44	5.38	3.22	1.25	N/A	1.25	6.25	85.9
10000	4.96	9.44	4.13	1.06	18.50	3/4 NPT	2.84	9.81	6.00	4.91	1.50	N/A	1.28	7.06	187.3

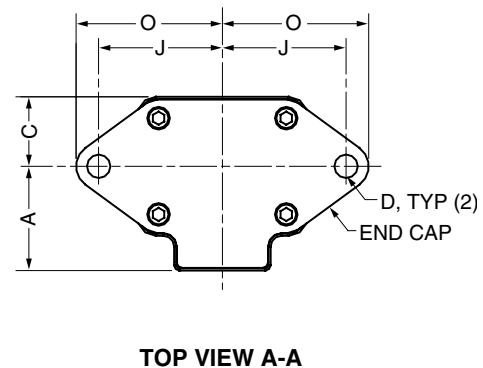
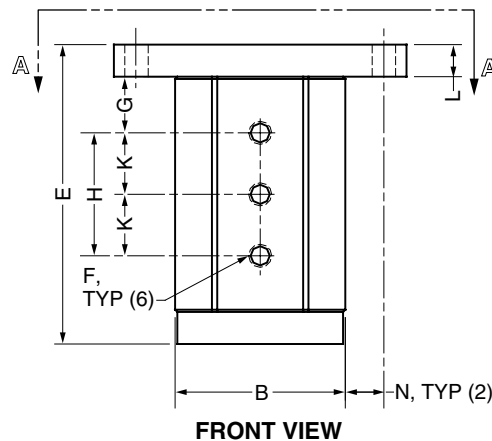
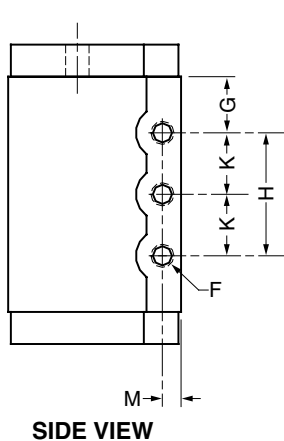

Specifications subject to change without notice.

VMAX™ and Posi-plate® are trademarks of Posi-plate, St. Paul, Minnesota.

© Posi-plate, 2013 • Bulletin 20901-1